

### 13A Green Indicator - Grid Module

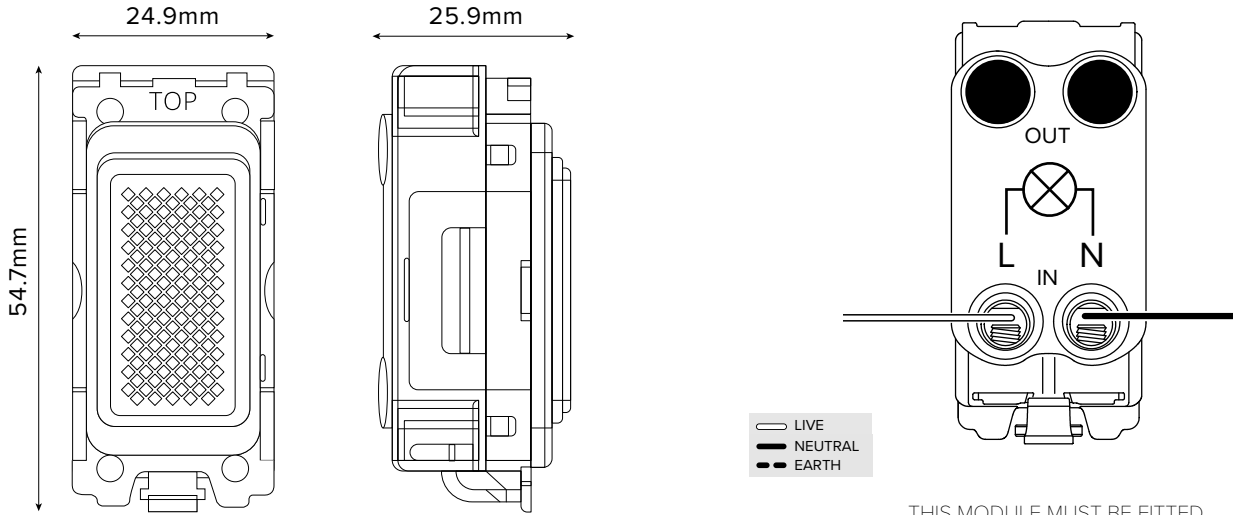

THIS MODULE MUST BE FITTED TO AN EARTHED FACE PLATE

#### TECHNICAL SPECIFICATION

Standard(s)	BS 5733
Voltage Rating	13 Amp, 250V~
Mounting Box Depth (Min)	35mm
Terminal Capacity	4 x 2.5mm <sup>2</sup> , 2 x 2.5mm <sup>2</sup> & 1 x 4.0mm <sup>2</sup>
Size	55mm x 25mm x 26mm
Product Class 1	Face plate must be earthed
Ambient Operating Temperature	-5° to +40°C
Recommended Location	Internal Use Only
Maximum Installation Altitude	2000m
IP Rating	IP2XD
Mains Frequency	50hz - 60hz
Trademarks	The Soho Lighting Company is a registered trade mark number: UK00003313349, EU017906396, Date: 25 May 2018