

Blank Plate - Euro Module

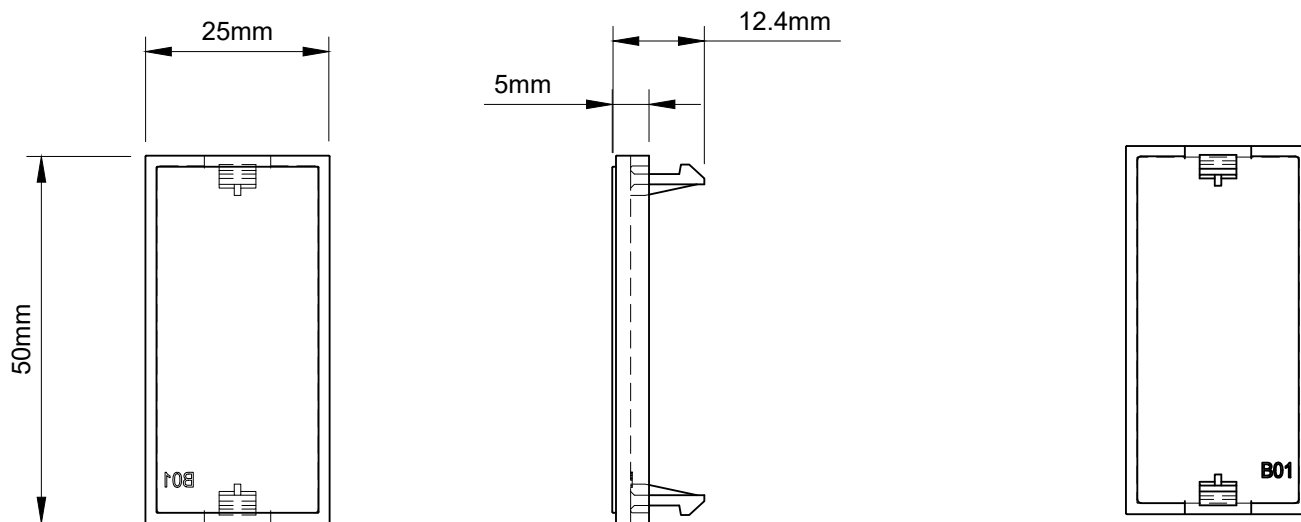

TECHNICAL SPECIFICATION

Standard(s)	BS 5733
Mounting Box Depth (Min)	35mm
Size	50mm x 25mm x 12.5mm
Product Class 1	Face plate must be earthed
Ambient Operating Temperature	-5° to +40°C
Recommended Location	Internal Use Only
Maximum Installation Altitude	2000m
IP Rating	IP2XD
Mains Frequency	50hz - 60hz
Trademarks	The Soho Lighting Company is a registered trade mark number: UK00003313349, EU017906396, Date: 25 May 2018