

### 13A Switched Fuse - Edged Plate

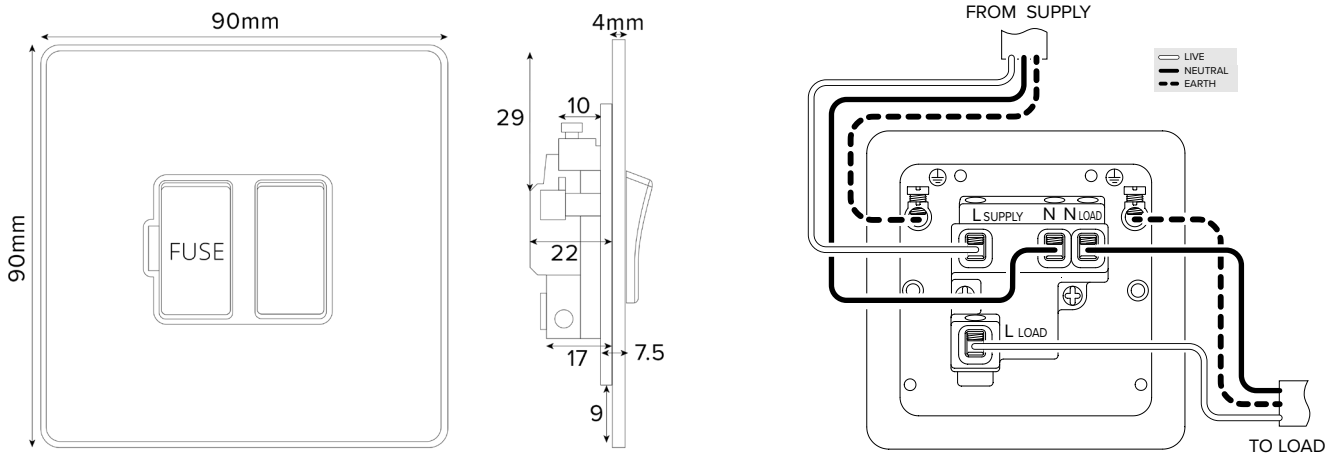

#### TECHNICAL SPECIFICATION

Standard(s)	BS1363-4
Voltage Rating	13 Amp, 250V~
Switch Type	Double Pole
Contact Gap	Normal Gap
Mounting Box Depth (Min)	25mm
Terminal Capacity	3 x 2.5mm <sup>2</sup> , 3 x 4.0mm <sup>2</sup> , 2 x 6.0mm <sup>2</sup> (L&N)
Earth Terminal Capacity	3x 2.5mm <sup>2</sup> , 2 x 4.0mm <sup>2</sup> , 1 x 6.0mm <sup>2</sup> (Earth)
Fixing Centres	60.3mm
Size	90mm x 90mm x 4mm (Plate thickness)
Product Class 1	Face plate must be earthed
Ambient Operating Temperature	-5° to +40°C
Recommended Location	Internal Use Only
Maximum Installation Altitude	2000m
IP Rating	IP2XD
Switched Poles	Double
Mains Frequency	50hz - 60hz
Contact Gap Minimum	3mm
Trademarks	The Soho Lighting Company is a registered trade mark number: UK00003313349, EU017906396, Date: 25 May 2018