

10-PLT304

4 Gang Toggle Grid Plate - Flat Plate

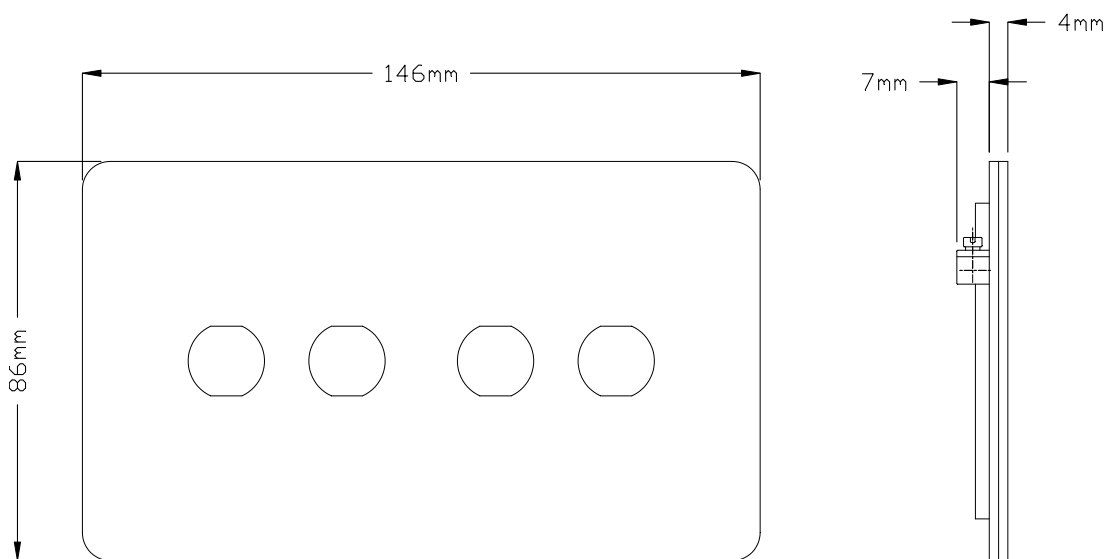

INSTRUCTIONS

1. Place module into rear of plate and screw into place with the included screws.
2. For Screw-less Decorative range, snap the front plate onto plastic surround.
3. Fit toggle ring with the included tool.

TECHNICAL SPECIFICATION

Standard(s)	BS 5733 (Where Applicable)
Mounting Box Depth (Min)	35mm
Earth Terminal Capacity	3 x 2.5mm ² , 2 x 4.0mm ² , 1 x 6.0mm ² (EARTH)
Fixing Centres	120.6mm
Size	86mm x 146mm x 4mm (Plate thickness)
Product Class 1	Face plate must be earthed
Ambient Operating Temperature	-5° to +40°C
Recommended Location	Internal Use Only
Maximum Installation Altitude	2000m
IP Rating	IP2XD
Trademarks	The Soho Lighting Company is a registered trade mark number: UK00003313349, EU017906396, Date: 25 May 2018